

QUEST LED EVO M HB NT 16150LM DALI I KL. IP67 740 120D 93W

SZCZEGÓŁOWA KARTA PRODUKTU



PARAMETRY TECHNICZNE

Indeks:	845031
Stopień szczelności:	IP67
Moc znamionowa oprawy [W]*:	93
Strumień świetlny oprawy [lm]*:	16150
Temperatura barwowa [K]:	4000
Wskaźnik oddawania barw (Ra) >:	70
SDCM:	3
Klasa ochronności:	I
Klasa energetyczna:	B
Materiał korpusu:	aluminium

CHARAKTERYSTYKA

Quest LED EVO M, their high-bay versions: surface-mounted Quest LED EVO M HB NT and suspended Quest LED EVO M HB Z are extremely efficient floodlights and premium HB class luminaires, manufactured in Poland. Their body is made of die-cast aluminium, powder coated, without an external heat sink and ribs that make it difficult to keep clean. The diffuser is made of tempered glass, under which there are LEDs with the highest efficiency. Different types of optics, especially asymmetrical ones, provide great freedom in choosing the right solution for a specific application. Thanks to the highest tightness rating on the market (IP67) and maximum impact resistance (IK10), the floodlights will perform well in all conditions, regardless of the weather and installation location. The new version of the renowned and proven QUEST model offers even better lighting parameters, achieving an efficiency of over 170 lm/W. Quest LED EVO M meets the requirements of PN-EN 60598-2 part 5, which allows it to be classified as an illumination projector, enabling complete freedom of installation in any position, with 360° rotation and resistance to strong winds. An additional advantage for contractors is the sealed quick connector – an innovative solution that eliminates traditional, time-consuming connection methods. Thanks to an intuitive system of coloured latches, connector installation is simple, quick and tool-free. The HB NT version is designed for surface mounting as a highbay using dedicated brackets. The HB Z version is designed for suspension. The accessory kit includes brackets for pole mounting, a frame for flush mounting (e.g. shelters), light pollution reduction screens and protective grids in two colours with different degrees of light reduction (white RAL7016: 4%, body colour RAL7016: 8%). The models can be equipped with an external motion and twilight sensor. They are also available in the ENDURA version, resistant to elevated ambient temperatures up to 50°C. The range also includes dual-module versions with increased flux and power. DALI versions are available (in the case of a gap in a specific power rating in the range with a DALI power supply, check the ENDURA DALI versions). In addition, a version designed for RGB+W illumination is available.

ZASTOSOWANIE

Quest LED EVO M is widely used in lighting educational, administrative and recreational facilities, halls, garages, passageways, warehouses, shops, as well as in the food industry and commercial and service facilities related to food products. They are an ideal solution for illuminating buildings, small sports fields, open spaces and car parks. They can be mounted as floodlights on poles and masts, on building facades, as well as surface-mounted highbays (HB NT version) and suspended highbays (HB Z version). Thanks to the flush-mounted option, they are perfect for shelters. Quest LED EVO M is an excellent choice for factories, production halls and large warehouses.

QUEST LED EVO M HB NT 16150LM DALI I KL. IP67 740 120D 93W

SZCZEGÓŁOWA KARTA PRODUKTU

TABELA PARAMETRÓW TECHNICZNYCH

Indeks:	845031	Wymiary (W/S/G/Z) [mm]:	424/635/152
EAN:	5905963845031	Wymiary montażowe [mm]:	590/45
Źródło światła:	LED	Stopień szczelności:	IP67
Moc znamionowa oprawy [W]:	93	Sposób montażu:	natynkowy
Strumień świetlny oprawy [lm]:	16150	Temperatura pracy [°C]:	od -20 do +35
Znamionowe napięcie zasilania [V]:	220 - 240	DIMM DALI:	tak
Zabezpieczenie przeciwprzepięciowe [kV]:	6	Liczba jednostek osprzętu:	1
Zakres napięć AC [V]:	198-264	Wymiary kartonu pojedynczego (W/S/G) [mm]:	550
Zakres napięć DC [V]:	176-280	Liczba sztuk na palecie [szt]:	48
Częstotliwość [Hz]:	50-60	Typ rozsyłu:	ogólny
Skuteczność świetlna oprawy [lm/W]:	174	Wersja:	M HB NT
Klasa energetyczna:	B	Odporność na uderzenia:	IK10
Klasa ochrony:	I	Żywotność LED L70B50 [h]:	162000
Temperatura barwowa [K]:	4000	Żywotność LED L80B10 [h]:	101000
Wskaźnik oddawania barw (Ra) >:	70	Żywotność LED L90B10 [h]:	47000
SDCM:	3	Gwarancja [lata]:	5
Kąt świecenia [°]:	120	Certyfikat CE:	79/2025
Materiał klosza:	szkło	Deklaracja środowiskowa (EPD):	816/2025
Rodzaj klosza:	transparentny	Instrukcja:	Pobierz PDF
Materiał korpusu:	aluminium	Plik LDT:	Pobierz
Kolor korpusu:	RAL7016		

QUEST LED EVO M HB NT 16150LM DALI I KL. IP67 740 120D 93W

SZCZEGÓŁOWA KARTA PRODUKTU
RYSUNKI TECHNICZNE

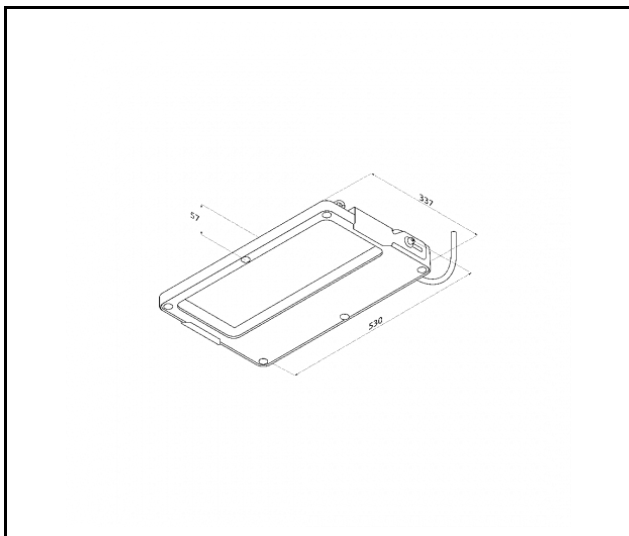

QUEST LED EVO M HB NT 16150LM DALI I KL. IP67 740 120D 93W

SZCZEGÓŁOWA KARTA PRODUKTU

DOSTĘPNE AKCESORIA

indeks	Nazwa
840432	QUEST LED EVO M siatka ochronna RAL7016
840074	QUEST LED EVO M siatka ochronna RAL9003
840388	QUEST LED EVO M/L zestaw RCR 1x
840371	QUEST LED EVO M/L zestaw RCR 2x



QUEST LED EVO M siatka ochronna RAL7016 (840432)



QUEST LED EVO M siatka ochronna RAL9003 (840074)



QUEST LED EVO M/L zestaw RCR 1x (840388)



QUEST LED EVO M/L zestaw RCR 2x (840371)

Data utworzenia karty: 05 wrzesień 2025

Producent zastrzega sobie prawo do zmian w toku udoskonalenia produktów oraz do zmian konstrukcyjnych lub modernizacji w prezentowanym produkcie. Oprawa spełnia warunki dyrektywy unijnej ROHS 2001/65/UE. Karta techniczna produktu nie jest ofertą handlową. *Tolerancja parametru wynosi +/- 10%.



Ten produkt podlega zasadom recyklingu sprzętu elektrycznego i elektronicznego



Certyfikat CE - Nr:79/2025